

LINHA DE PORTÕES

CATÁLOGO
PERFIS DE ALUMÍNIO



DEZEMBRO / 2017

CÓDIGO PERFIL	PESO (KG/M)	PÁGINA
BARRAS REDONDAS	-	01
BARRAS QUADRADAS	-	01
BARRAS RETANGULARES	-	01
CANTONEIRAS	-	02
PERFIS T	-	02
PERFIS U DESIGUAIS	-	02
PERFIS U IGUAIS	-	03
TUBOS QUADRADOS	-	03
TUBOS REDONDOS	-	03
TUBOS RETANGULARES	-	04
CHAPA LISA	-	04
CHAPA XADREZ	-	04
29-160	1,398	10
39-811	3,111	10
A-213	0,274	13
CG-087G	0,427	06
D-042	1,555	05
D-055	0,580	07
D-056	0,343	06
D-069	1,110	05
D-070	0,256	06
D-078	0,795	05
D-079	0,563	05
D-080	0,524	07
D-081	0,643	07
D-082	0,349	06
D-102	0,627	05
D-103	0,786	07

CÓDIGO PERFIL	PESO (KG/M)	PÁGINA
D-777	0,974	06
D-778	0,897	06
E-362	0,636	11
E-363	1,108	11
E-364	0,458	12
E-365	0,656	12
LB-034	0,960	9
LB-038	1,022	8
LB-070	1,018	8
LB-080	0,620	9
PC-010	1,119	7
PU-639	0,400	13
U-1058	0,085	7
U-1098	0,494	11
U-1244	0,245	11
U-482	0,115	13
U-4848	1,308	11
U-495	0,163	13
U-990	0,635	11
VZ-060	0,397	13
VZ-063	0,263	13
Y-181	0,570	12
Y-335	0,841	9
Y-355	0,871	9
Y-429	0,685	9
Z-033	0,350	12
Z-063	0,325	12
Z-175	0,572	12

Barras Redondas

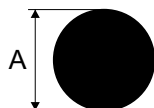

PERFIL	PESO LINEAR KG/M	MM	POLEGADA
		A	A
VER-002	0,086	6,35	1/4
VER-004	0,133	7,93	5/16
VER-007	0,193	9,52	3/8
VER-011	0,342	12,70	1/2
VER-014	0,536	15,87	5/8
VER-016	0,772	19,05	3/4
VER-018	1,050	22,22	7/8
VER-021	1,371	25,40	1
VER-024	1,735	28,57	1.1/8
VER-032	3,078	38,10	1.1/2
VER-040	5,490	50,80	2
VER-042	8,850	63,50	2.1/2
VER-043	12,320	76,20	3

* PARA USINAGEM LIGA 6351 T6

* PARA CAIXILHARIA LIGA 6063 T5

Barras Retangulares

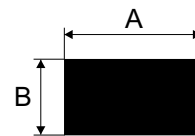

PERFIL	PESO LINEAR KG/M	MM		POLEGADA	
		A	B	A	B
BAR-010	0,082	9,58	3,17	3/8	1/8
BAR-012	0,109	12,70	3,17	1/2	1/8
BAR-047	0,163	12,70	4,76	1/2	3/16
BAR-086	0,217	12,70	6,35	1/2	1/4
BAR-013	0,136	15,87	3,17	5/8	1/8
BAR-049	0,204	15,87	4,76	5/8	3/16
BAR-088	0,272	15,87	6,35	5/8	1/4
BAR-014	0,164	19,05	3,17	3/4	1/8
BAR-050	0,245	19,05	4,76	3/4	3/16
BAR-089	0,326	19,05	6,35	3/4	1/4
BAR-015	0,191	22,22	3,17	7/8	1/8
BAR-052	0,286	22,22	4,76	7/8	3/16
BAR-214	0,135	25,40	2,00	1	-
BAR-016	0,218	25,40	3,17	1	1/8
BAR-053	0,326	25,40	4,76	1	3/16
BAR-091	0,435	25,40	6,35	1	1/4
BAR-129	0,650	25,40	9,52	1	3/8
BAR-019	0,273	31,75	3,17	1.1/4	1/8
BAR-054	0,408	31,75	4,76	1.1/4	3/16
BAR-093	0,544	31,75	6,35	1.1/4	1/4
BAR-022	0,327	38,10	3,17	1.1/2	1/8
BAR-057	0,490	38,10	4,76	1.1/2	3/16
BAR-096	0,653	38,10	6,35	1.1/2	1/4
BAR-134	0,980	38,10	9,52	1.1/2	3/8
BAR-164	1,306	38,10	12,70	1.1/2	1/2
BAR-027	0,436	50,80	3,17	2	1/8
BAR-061	0,653	50,80	4,76	2	3/16
BAR-100	0,870	50,80	6,35	2	1/4
BAR-064	0,816	63,50	4,76	2.1/2	3/16
BAR-032	0,654	76,20	3,17	3	1/8
BAR-068	0,979	76,20	4,76	3	3/16
BAR-106	1,306	76,20	6,35	3	1/4
BAR-144	1,957	76,20	9,52	3	3/8
BAR-175	2,635	76,20	12,70	3	1/2
BAR-036	0,872	101,60	3,17	4	1/8
BAR-110	1,741	101,60	6,35	4	1/4
BAR-149	2,611	101,60	9,52	4	3/8
BAR-180	3,483	101,60	12,70	4	1/2
BAR-114	2,612	152,40	6,35	6	1/4

Barras Quadradas

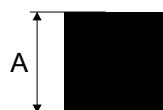

PERFIL	PESO LINEAR KG/M	MM	POLEGADA
		A	A
VER-4002	0,110	6,35	1/4
VER-4003	0,170	7,93	5/16
VER-4006	0,246	9,52	3/8
VER-4008	0,435	12,70	1/2
VER-4011	0,680	15,87	5/8
VER-4017	1,742	25,40	1

Perfis Tabelados

Cantoneiras de abas desiguais

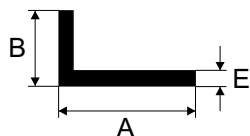

PERFIL	PESO LINEAR KG/M	MM			POLEGADA		
		A	B	E	A	B	E
L-001	0,118	25,00	11,00	1,30	-	-	-
L-093	0,300	25,40	12,70	3,17	1	1/2	1/8
L-581	0,160	32,00	16,20	1,20	-	-	-
L-100	0,521	38,10	25,40	3,17	1.1/2	1	1/8
L-23016	0,350	50,00	14,00	2	-	-	-
L-104	0,600	50,80	25,40	3,17	2	1	1/8
L-668	0,436	50,80	31,75	2,0	2	1.1/4	-
L-778	0,850	76,20	25,40	3,17	3	1	1/8
L-780	1,311	101,60	50,80	3,17	4	2	1/8

Cantoneiras de abas iguais

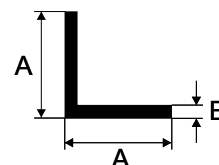

PERFIL	PESO LINEAR KG/M	MM		POLEGADA	
		A	E	A	E
L-641	0,073	12,70	1,10	1/2	-
L-002	0,100	12,70	1,58	1/2	1/16
L-643	0,076	15,87	1,00	5/8	-
L-405	0,130	15,87	1,58	5/8	1/16
L-644	0,092	19,05	1,00	3/4	-
L-009	0,150	19,05	1,58	3/4	1/16
L-011	0,300	19,05	3,17	3/4	1/8
L-642	0,122	25,40	1,00	1	-
L-013	0,210	25,40	1,58	1	1/16
L-014	0,410	25,40	3,17	-	1/8
L-015	0,598	25,40	4,76	1	3/16
L-3216	0,268	31,75	1,58	1.1/4	1/16
L-018	0,515	31,75	3,17	1.1/4	1/8
L-019	0,750	31,75	4,76	1.1/4	3/16
L-744	0,317	38,10	1,58	1.1/2	1/16
L-022	0,620	38,10	3,17	1.1/2	1/8
L-023	0,910	38,10	4,76	1.1/2	3/16
L-612	0,540	50,80	2,00	2	-
L-025	0,840	50,80	3,17	2	1/8
L-026	1,240	50,80	4,76	2	3/16
L-027	1,620	50,80	6,35	2	1/4
L-457	1,074	63,50	3,17	2.1/2	1/8
L-029	2,060	63,50	6,35	2.1/2	1/4
L-749	2,505	76,20	6,35	3	1/4

Perfis T

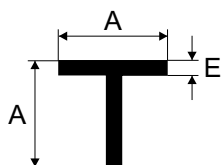

PERFIL	PESO LINEAR KG/M	MM		POLEGADA	
		A	E	A	E
T-002	0,100	12,70	1,58	1/2	1/16
T-123	0,162	25,40	1,20	1	-
T-076	0,213	25,40	1,58	1	1/16
T-021	0,633	38,10	3,17	1.1/2	1/8
T-023	0,845	50,80	3,17	2	1/8

Perfis U de abas iguais

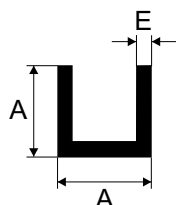

PERFIL	PESO LINEAR KG/M	MM		POLEGADA	
		A	E	A	E
U-841	0,084	9,52	1,20	3/8	-
U-036	0,108	9,52	1,58	3/8	1/16
U-1035	0,089	12,70	0,90	1/2	-
U-044	0,151	12,70	1,58	1/2	1/16
U-509	0,192	15,87	1,58	5/8	1/16
U-1582	0,234	22,22	1,30	7/8	-
U-245	0,320	25,40	1,58	1	1/16

Perfis U de abas desiguais

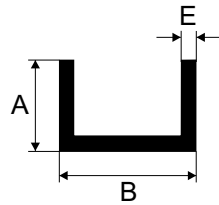

PERFIL	PESO LINEAR KG/M	MM			POLEGADA		
		A	B	E	A	B	E
U-786	0,100	12,70	9,52	1,20	1/2	3/8	-
U-037	0,130	12,70	9,52	1,58	1/2	3/8	1/16
U-056	0,200	12,70	19,05	1,70	1/2	3/4	-
U-1211	0,270	12,70	25,40	1,58	1/2	1	1/16
U-069	0,380	12,70	25,40	3,17	1/2	1	-
U-041	0,130	15,00	11,10	1,20	-	-	-
U-1178	0,135	15,00	14,00	1,20	-	-	-
U-627	0,200	19,05	12,70	1,58	3/4	1/2	1/16
VT-727	0,130	20,00	10,70	1,00	-	-	-
U-398	0,155	20,00	10,70	1,00	-	-	-
U-606	0,154	22,00	11,00	1,20	-	-	-
U-607	0,162	22,00	14,00	1,20	-	-	-
U-2514	0,165	25,00	14,00	1,00	-	-	-
U-555	0,230	25,00	15,00	1,35	-	-	-
U-087	0,810	25,40	50,80	3,17	1	2	1/8
U-091	1,030	25,40	76,20	3,17	1	3	1/8
PU-639	0,400	35,00	29,00	1,50	-	-	-
U-4814	0,360	48,00	14,40	1,35	-	-	-
U-093	1,680	50,80	101,60	3,17	2	4	1/8

Tubos Redondos

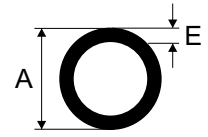

PERFIL	PESO LINEAR KG/M	MM		POLEGADA	
		A	E	A	E
TUB-001	0,074	9,52	1,00	3/8	-
TUB-003	0,108	9,52	1,58	3/8	1/16
TUB-008	0,100	12,70	1,00	1/2	-
TUB-009	0,121	12,70	1,24	1/2	-
TUB-018	0,160	15,87	1,24	5/8	-
TUB-026	0,155	19,05	1,00	3/4	-
TUB-027	0,184	19,05	1,24	3/4	-
TUB-030	0,426	19,05	3,17	3/4	1/8
TUB-036	0,183	22,22	1,00	7/8	-
TUB-038	0,282	22,22	1,58	7/8	1/16
TUB-045	0,254	25,40	1,24	1	-
TUB-046	0,320	25,40	1,58	1	1/16
TUB-048	0,600	25,40	3,17	1	1/8
TUB-053	0,364	28,57	1,58	1.1/8	1/16
TUB-058	0,405	31,75	1,58	1.1/4	1/16
TUB-061	0,770	31,75	3,17	1.1/4	1/8
TUB-069	0,494	38,10	1,58	1.1/2	1/16
TUB-070	0,942	38,10	3,17	1.1/2	1/8
TUB-Y0018	0,645	50,80	1,40	2	-
TUB-610	0,670	50,80	1,58	2	1/16
TUB-091	0,826	50,80	2,00	2	-
TUB-092	1,285	50,80	3,17	2	1/8
TUB-156	0,650	63,50	1,24	2.1/2	-
TUB-635	1,050	76,20	1,65	3	-
TUB-636	1,260	76,20	2,00	3	-
TUB-167	1,990	76,20	3,17	3	1/8
TUB-278	1,404	101,60	1,65	4	-

Tubos Quadrados

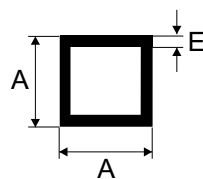

PERFIL	PESO LINEAR KG/M	MM		POLEGADA	
		A	E	A	E
TUB-4001	0,200	12,70	1,58	1/2	1/16
TUB-4002	0,250	15,87	1,58	5/8	1/16
TUB-4051	0,196	19,05	1,00	3,4	-
TUB-4003	0,297	19,05	1,58	3,4	1/16
TUB-4061	0,263	25,40	1,00	1	-
TUB-4008	0,405	25,40	1,58	1	1/16
TUB-4071	0,759	25,40	3,17	1	1/8
TUB-4046	1,127	30,00	4,00	-	-
TUB-4011	0,515	31,75	1,58	1.1/4	1/16
TUB-4064	0,486	38,10	1,20	1.1/2	-
TUB-4014	0,624	38,10	1,58	1.1/2	1/16

TUB-4015	0,780	38,10	3,17	1.1/2	-
TUB-4049	1,203	38,10	3,17	1.1/2	1/8
TUB-4120	0,850	50,80	1,58	2	1/16
TUB-4020	1,055	50,80	2,00	2	-
TUB-4048	1,640	50,80	3,17	2	1/8
TUB-4715	2,390	50,80	4,76	2	3/16
TUB-4033	1,610	76,20	2,00	3	-
TUB-4054	2,686	101,60	2,50	4	-
TUB-4025	4,015	101,60	3,80	4	-

Perfis Tabelados

Tubos retangulares

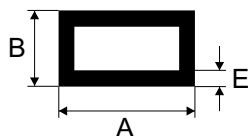

PERFIL	PESO LINEAR KG/M	MM			POLEGADA		
		A	B	E	A	B	E
TUB-4704	0,200	25,40	12,70	1,00	1	1/2	-
TUB-4501	0,310	25,40	12,70	1,58	1	1/2	1/16
TUB-4509	0,497	30,00	20,00	2,0	-	-	-
TUB-4710	0,430	38,10	19,05	1,45	1.1/2	3/4	-
TUB-4586	0,874	38,10	19,05	3,17	1.1/2	3/4	1/8
TUB-4545	0,645	38,10	25,40	2,00	1.1/2	1	-
TUB-4536	0,430	50,80	12,70	1,30	2	1/2	-
TUB-4588	0,410	50,80	25,40	1,00	2	1	-
TUB-4560	0,630	50,80	25,40	1,50	2	1	-
TUB-4504	0,810	50,80	25,40	2,00	2	1	-
TUB-4589	1,201	50,80	25,40	3,17	2	1	1/8
TUB-4718	0,700	50,80	38,10	1,40	2	1.1/2	-
TUB-4513	0,918	50,80	38,10	2,00	2	1.1/2	-
TUB-4543	0,875	60,32	38,10	1,70	2.3/8	1.1/2	-
TUB-4707	0,983	76,20	38,10	1,50	3	1.1/2	-
TUB-4517	1,190	76,20	38,10	2,00	3	1.1/2	-
TUB-4518	1,858	76,20	38,10	3,17	3	1.1/2	1/8
TUB-4573	2,076	76,20	50,80	3,17	3	2	1/8
TUB-4537	1,760	101,60	38,10	2,40	4	1.1/2	-
TUB-4730	1,225	101,60	50,80	1,50	4	2	-
TUB-4599	1,770	101,60	50,80	2,00	4	2	-
TUB-4530	2,500	101,60	50,80	3,17	4	2	1/8
TUB-4520	3,181	152,40	38,10	3,20	6	1.1/2	1/8
TUB-4559	3,206	152,40	50,80	3,00	6	2	-
TUB-4728	4,566	152,40	76,20	3,50	6	3	-

Chapa lisa em alumínio

2000 X 1000 mm		2000 X 1250 mm		3000 X 1000 mm	
ESP.	PESO	ESP.	PESO	ESP.	PESO
0,50	2,700	0,60	4,050	0,70	7,087
0,60	3,240	0,70	4,725	1,00	10,125
0,70	3,780	0,80	5,400	1,20	12,150
0,80	4,320	1,00	6,750	1,50	15,187
1,00	5,400	1,20	8,100	2,00	20,250
1,20	6,480	1,50	10,125	3,00	30,375
1,50	8,100	2,00	13,500		
2,00	10,800	3,00	20,250		
2,50	13,500	4,00	27,000		
3,00	16,200				
4,00	21,600				

Chapa xadrez

2500 X 1000 mm	
ESP.	PESO (KG)
1,20	11,50
2,20	18,50
2,70	23,00

3000 X 1250 mm	
ESP.	PESO (KG)
1,20	19,00

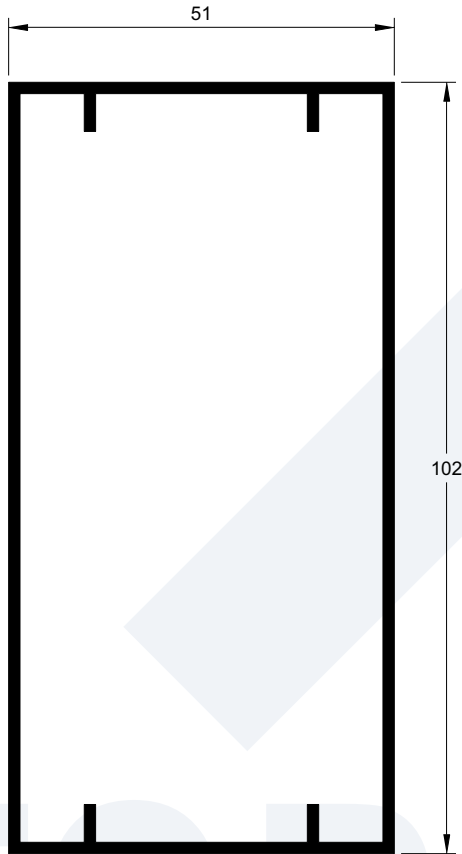

D-042

1,555 kg/m

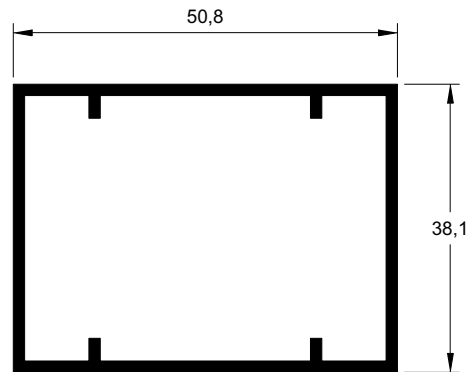

D-078

0,795 kg/m

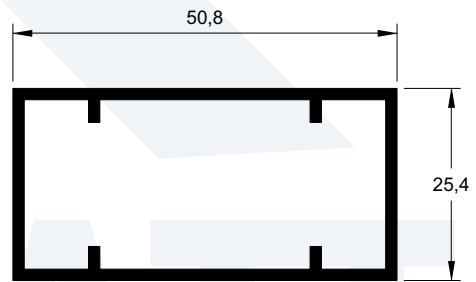

D-079

0,563 kg/m

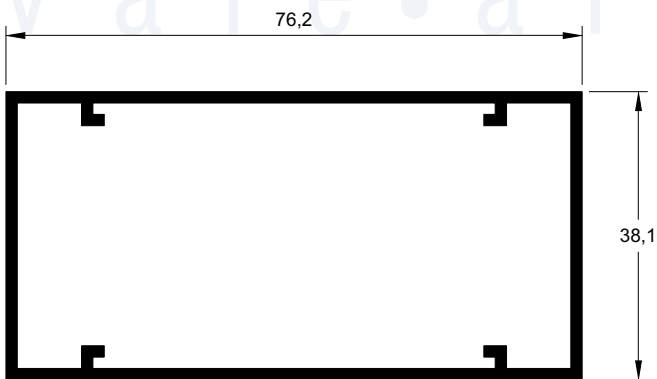

D-069

1,110 kg/m

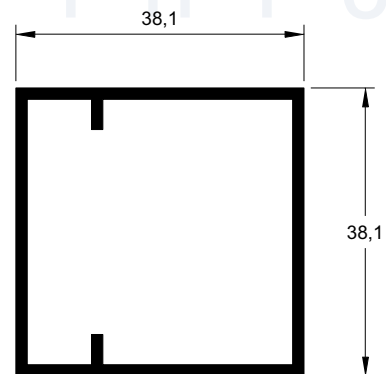

D-102

0,627 kg/m

Portões

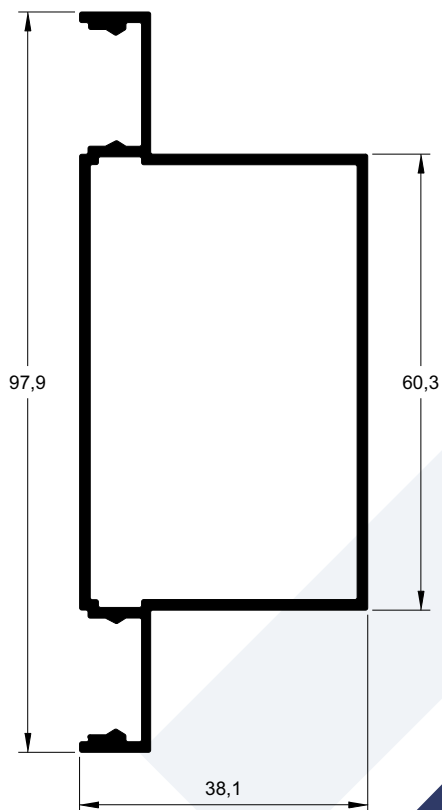

D-777
0,974 kg/m

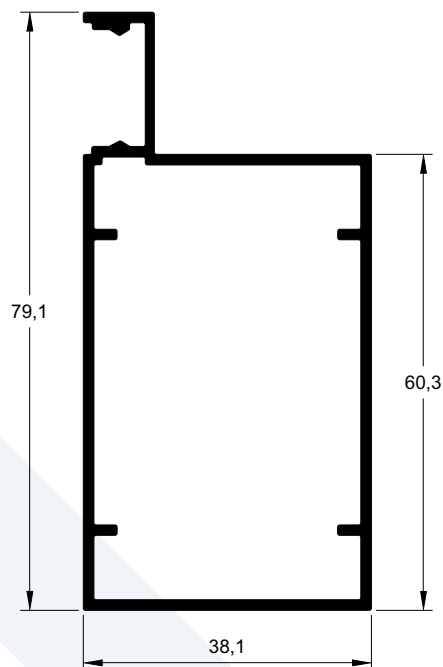

D-778
0,897 kg/m

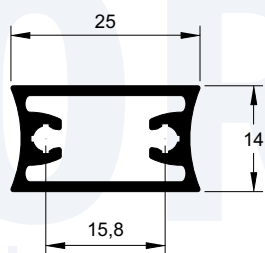

D-056
0,343 kg/m

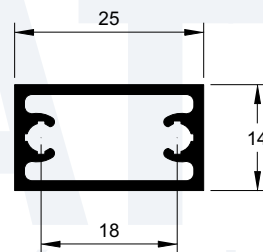

D-082
0,349 kg/m

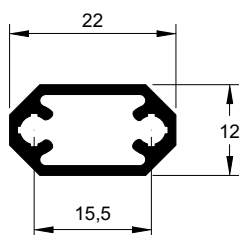

D-070
0,256 kg/m

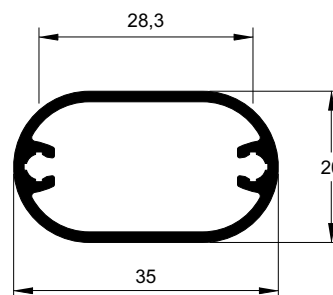

CG-087G
0,427 kg/m

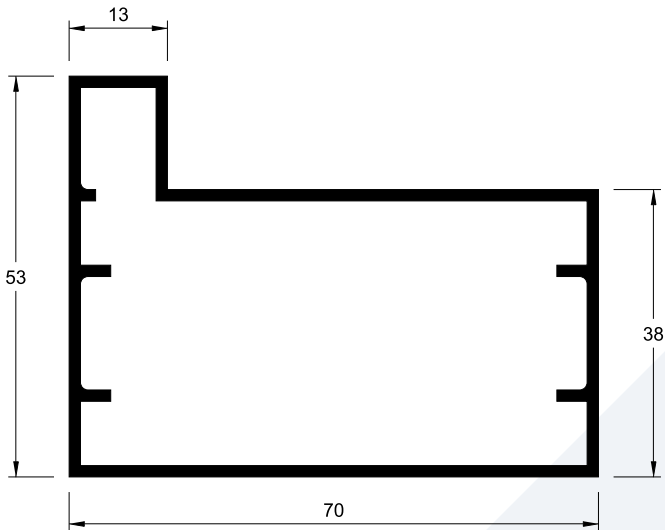

PC-010
1,119 kg/m

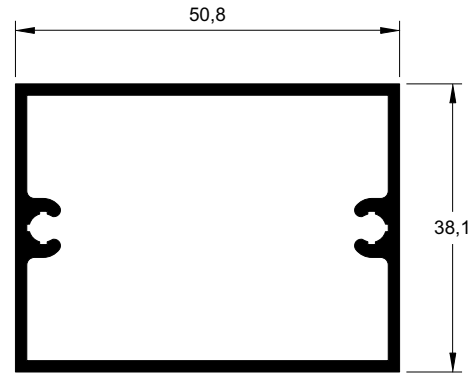

D-103
0,786 kg/m

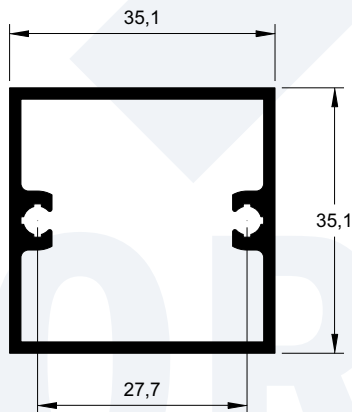

D-081
0,643 kg/m

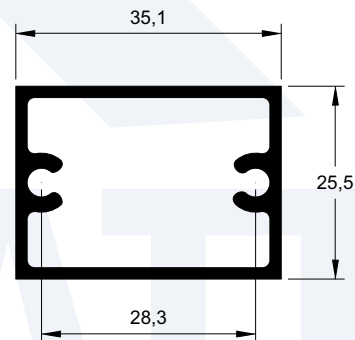

D-055
0,580 kg/m

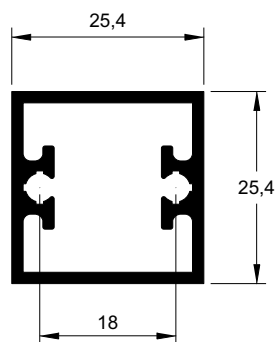

D-080
0,524 kg/m

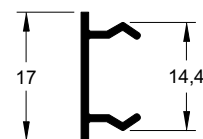

U-1058
0,085 kg/m

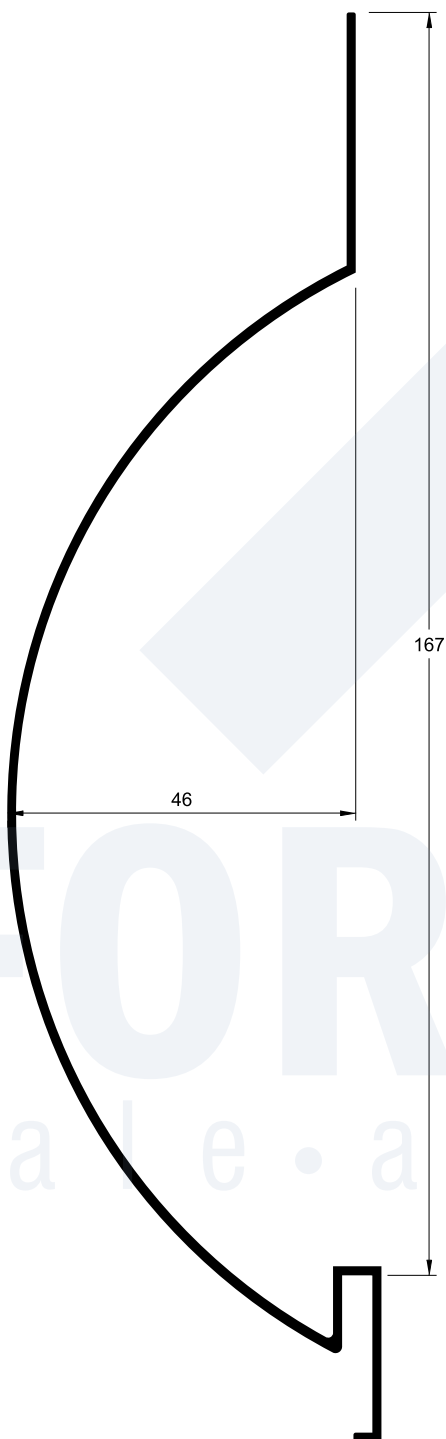

LB-038

1,022 kg/m

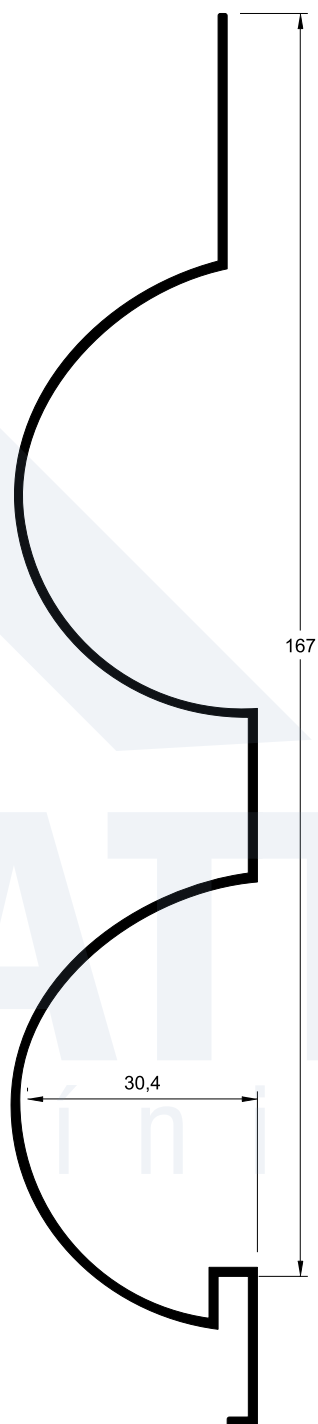

LB-070

1,018 kg/m



Y-355

0,871 kg/m

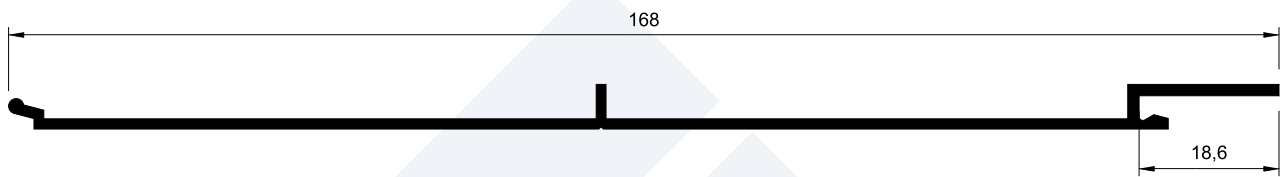

Y-335

0,841 kg/m

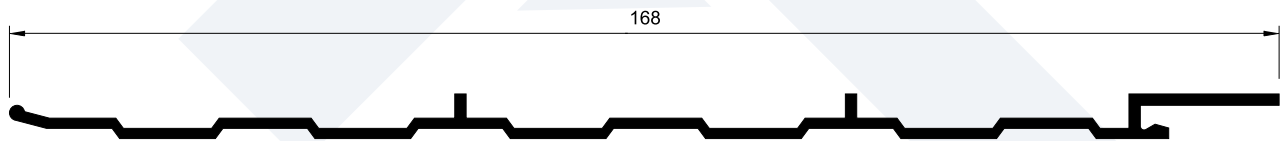

Y-429

0,685 kg/m

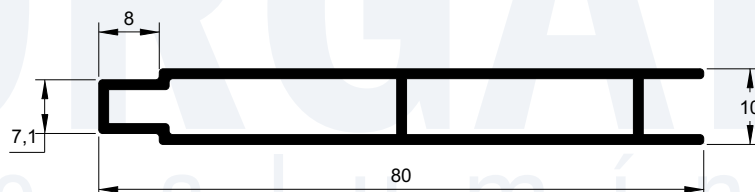

LB-080

0,620 kg/m

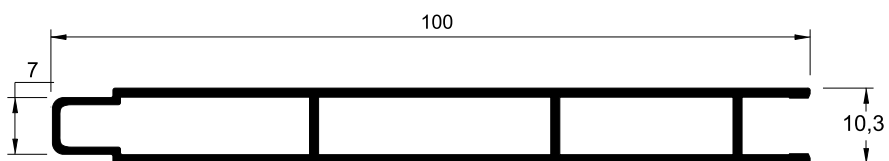

LB-034

0,960 kg/m

Portões

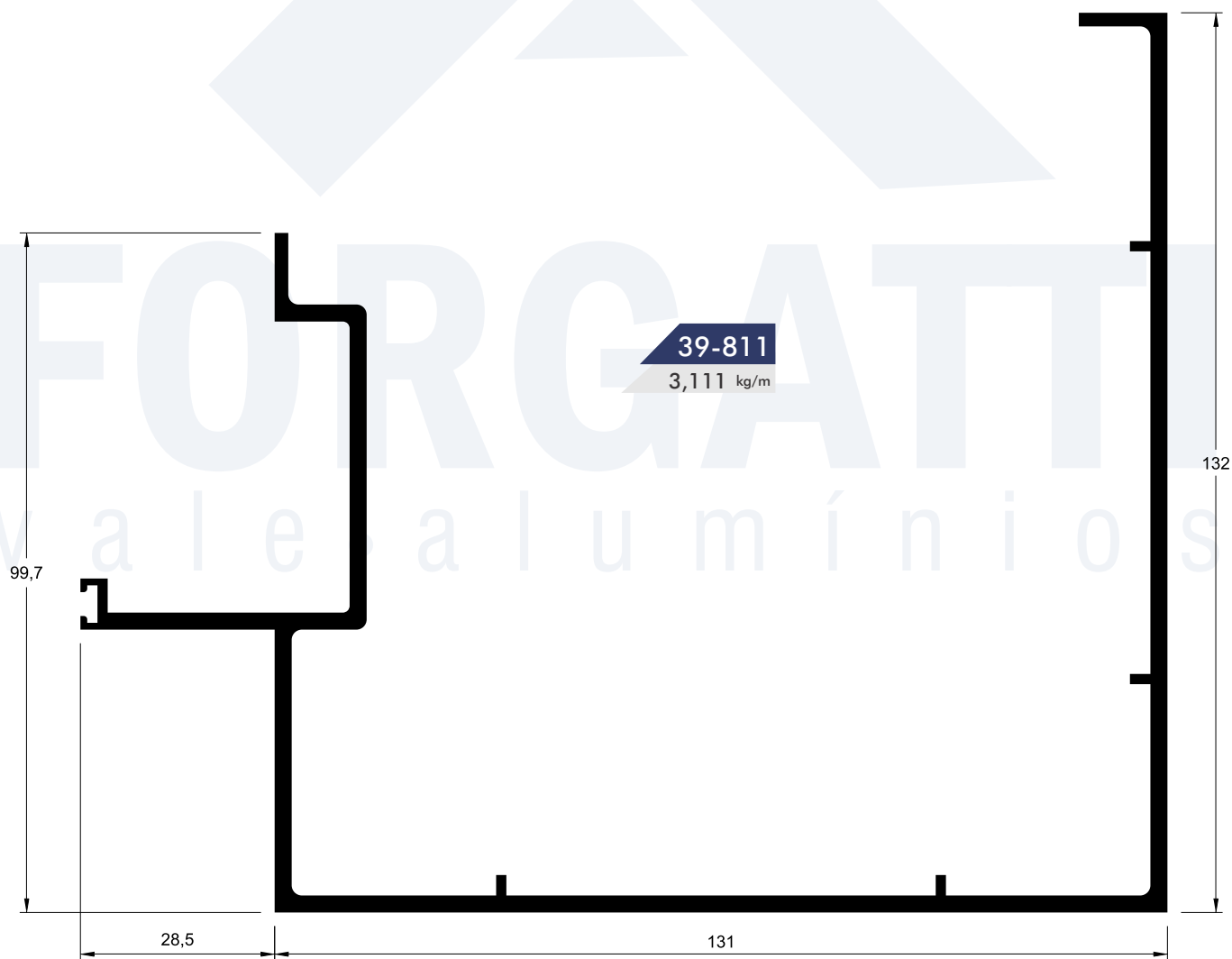
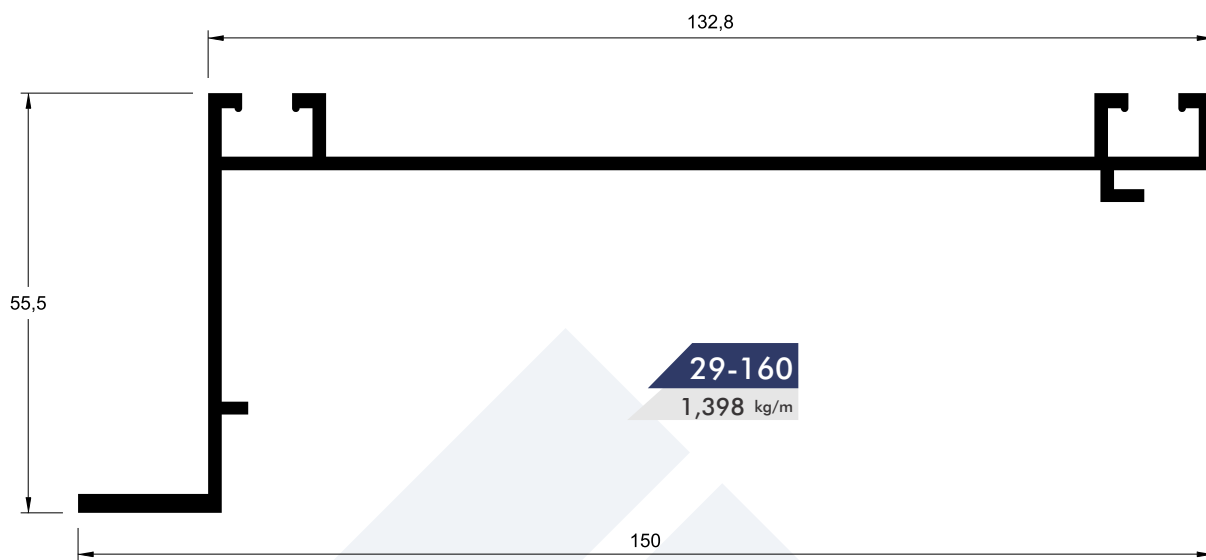

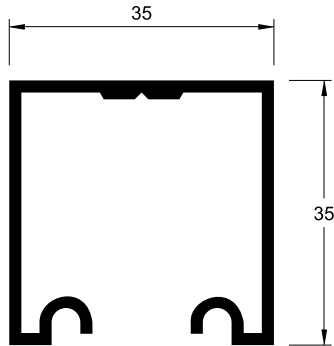

U-1098
0,494 kg/m

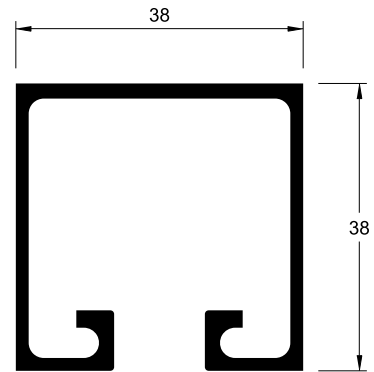

U-990
0,635 kg/m

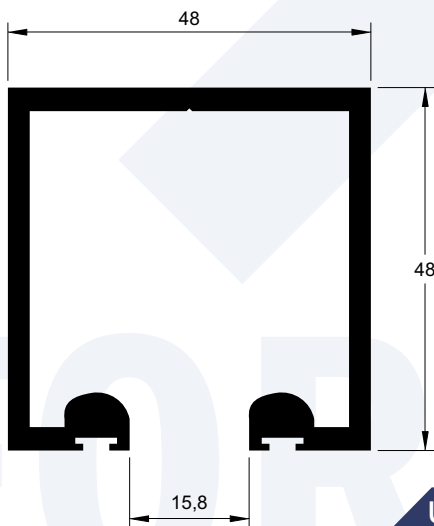

U-4848
1,308 kg/m

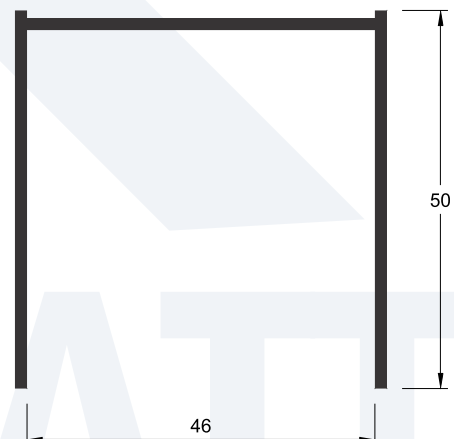

E-362
0,636 kg/m

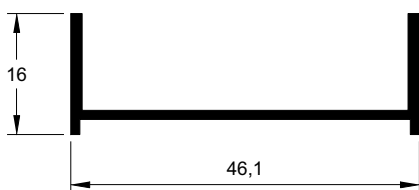

U-1244
0,245 kg/m

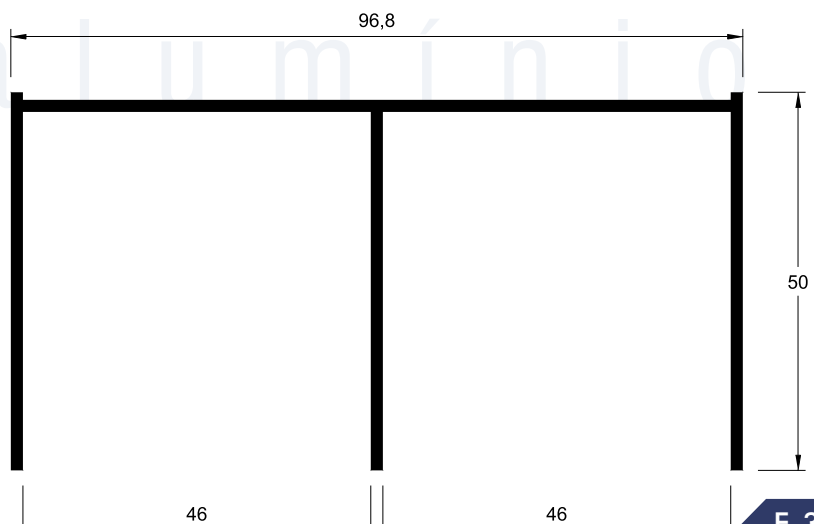

E-363
1,108 kg/m

Portões

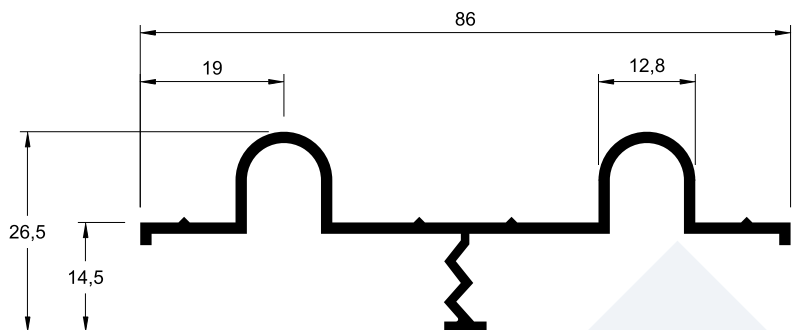

E-365
0,656 kg/m

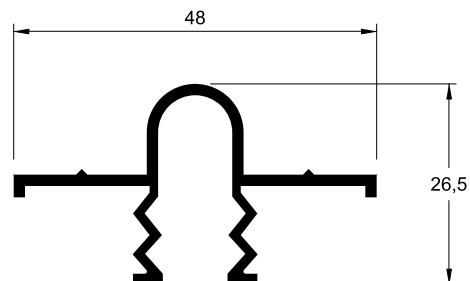

E-364
0,458 kg/m

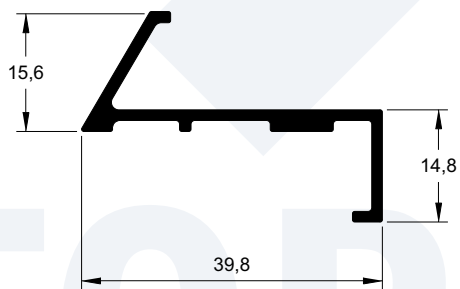

Z-033
0,350 kg/m

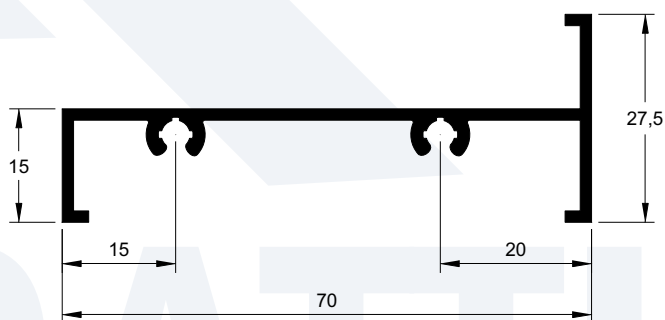

Z-175
0,572 kg/m

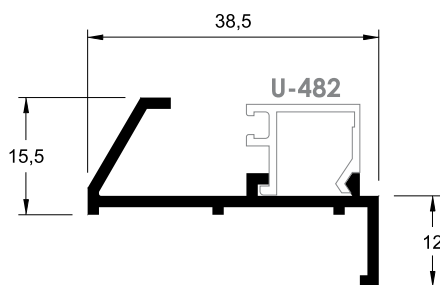

Z-063
0,325 kg/m

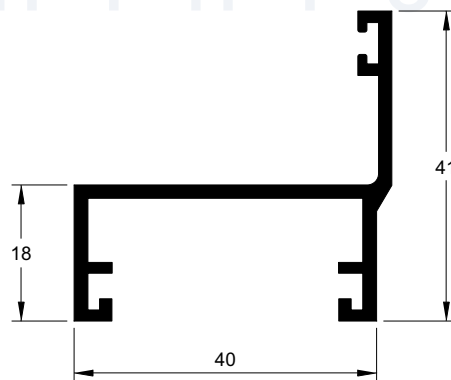

Y-181
0,570 kg/m

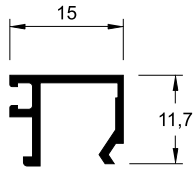

U-482

0,115 kg/m

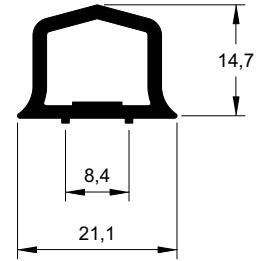

A-213

0,274 kg/m

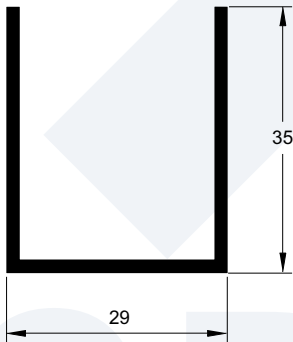

PU-639

0,400 kg/m

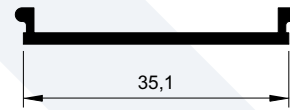

U-495

0,163 kg/m

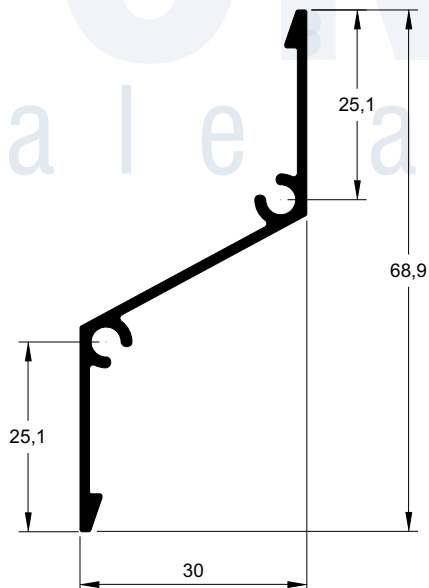

VZ-060

0,397 kg/m

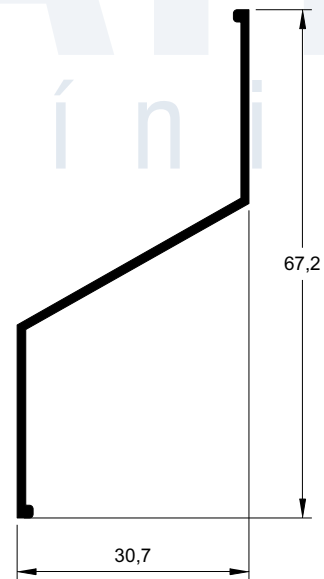

VZ-063

0,263 kg/m

**PERFIS BOX LISO E FRISADO
PERFIS PARA ESQUADRIAS, FACHADAS E OUTROS
CHAPA EM ALUMÍNIO / ACM
CHAPAS, TELHAS E VENEZIANA EM POLICARBONATO**

**KIT DE FERRAGENS PARA PORTÕES BASCULANTE
ACESSÓRIOS * COMPONENTES
ESCOVAS DE VEDAÇÃO * GUARNIÇÕES EM EPDM
PARAFUSOS * BUCHAS * REBITES
KITS PARA BOX**



Rua Koichi Matsumura, 132 - Jardim América - São José dos Campos / SP
CEP 12235-180 - TEL (12) 3931-3937
e-mail: forgattivale@uol.com.br - www.forgatti.com.br